

ECOWATER  
SYSTEMS®



Your Water. Perfected.

Let us

**Perfect**

your water and

**Protect**

your family.

## EACW

ALKALINE/REMINERALIZING, CHLORINE TASTE AND ODOR FILTER

### Alkaline/Remineralizing System

The EcoWater Systems model EACW increases the pH and remineralizes the water. It is designed for best performance to be installed in the line between the RO system's product water outlet and the product water dispensing faucet.

#### Here's How the EACW Works:

Water is directed through the EACW filter where it dissolves minerals to add flavor and raise pH. Chlorine taste and odor and sediment are reduced. The only thing left behind is pure, great tasting water and minerals that help improve the taste of filtered water.

#### Features and Benefits:

- Provides great tasting water for cooking and drinking – eliminates the need for bottled water.
- Raises pH to 9-10
- Compact design can attach directly to EWS385/375/175 Reverse Osmosis systems.
- Safe minerals are added to the water, improving taste and raising pH.
- Encapsulated replacement filters with sealed outer shell to ensure that every filter change is sanitary and dry.

**Raises pH  
Adds Minerals  
Improves Flavor**

**Reduces  
Chlorine  
Taste & Odor**



 Designed, Engineered &  
Assembled in the U.S.A.

ecowater.com

## DIMENSIONS

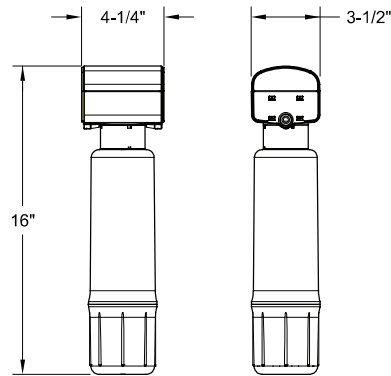

## SPECIFICATIONS

	EACW
Feed water pressure (min.-max.)	40-100 psi
Feed water temperature (min.-max.)	40-100°F/4-38°C
Flow rate (max.)	0.9 gpm
Maximum iron/manganese	0
Maximum hydrogen sulfide	0
Shipping weight	3 lbs.

\*Complies with NSF Standard 372.

**EACW: For best performance install after a reverse osmosis system.**

### WARRANTY

- Five years on the drinking water system for defects in material and workmanship.
- Cartridge performance is not covered by the warranty.



Your Water. Perfected.



EcoWater Systems LLC  
P.O. Box 64420  
St. Paul, MN 55164-0420